



**QLI FITNESS EQUIPMENT**

# 2026 CATALOGUE



**POWER YOUR LIFESTYLE**

AUSTRALIA | VIETNAM | USA

# ABOUT US

At QLI Fitness Equipment, we are redefining fitness innovation with our global presence and unwavering commitment to excellence. With **two state-of-the-art factories in Vietnam**, including a 30,000-square-meter facility and a brand new 45,000-square-meter factory, we bring unmatched manufacturing expertise to the global fitness market. Our team of over 400 skilled professionals, including experienced engineers, ensures every piece of equipment meets the highest standards of durability, performance, and style.

As a truly global company, we operate from three strategic headquarters in the **United States, Australia, and Vietnam**, allowing us to deliver premium fitness solutions seamlessly to customers worldwide. Powered by **advanced technologies and robotics**, our production process guarantees precision and quality. We offer **customization options** to tailor products to your brand and colour preferences for eligible container orders, making us the ideal partner for fitness businesses looking to stand out.



At QLI Fitness Equipment, we proudly offer a comprehensive warranty for our products, including a **5-year warranty** on steel frames and a **1-year warranty** covering accessories such as rubber components, padding, and bearings. Additionally, we provide **worldwide delivery**, ensuring that wherever you are, accessing premium fitness equipment to elevate your lifestyle is effortless and within reach.

# MISSION

*To empower fitness enthusiasts and businesses worldwide with innovative, customizable, and high quality equipment that transforms lives, enhances experiences, and elevates lifestyles.*

# VISION

*To become the world's leading provider of premium fitness solutions by leveraging advanced technologies, global expertise, and customer centric customization, setting the gold standard for innovation and excellence in the fitness industry.*

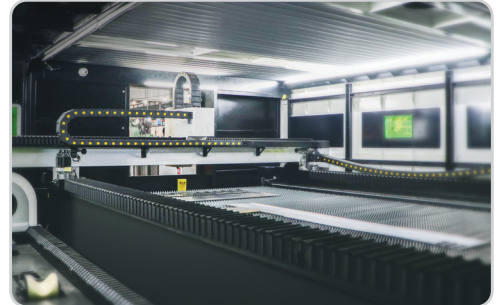
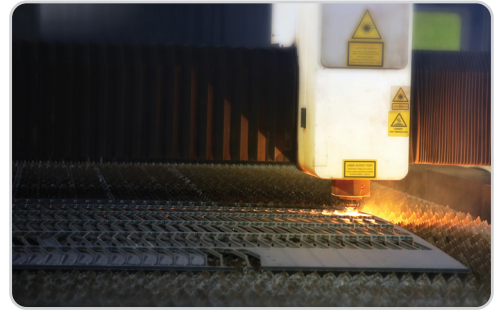

# FACTORY

*We create secure and effective working environments with the best machine. We go above and beyond to make sure that our customers stay happy with the good / services received from us.*

*We are constantly creative to deliver each customer high-quality products and services with trustworthiness, respect, and responsibility.*

# VALUES

**Innovation:** We embrace cutting-edge technologies and robotics to deliver unparalleled quality and performance.

**Customer Focus:** We prioritize the unique needs of our customers, offering tailored solutions that enhance their fitness journeys.

**Global Excellence:** With headquarters in the US, Australia, and Vietnam, we uphold a global standard of quality and service.

**Sustainability:** Our commitment to premium materials and efficient processes reflects our dedication to a healthier planet.

**Integrity:** We stand behind our products with a 3-year warranty and exceptional customer support, ensuring trust and reliability in every interaction.



CUSTOMIZED PRODUCTS

WORLDWIDE DELIVERY



# QUALITY CONTROL

Our process is designed to be robust, starting from the conceptualization and design engineering phase, all the way to assembly and quality inspection.

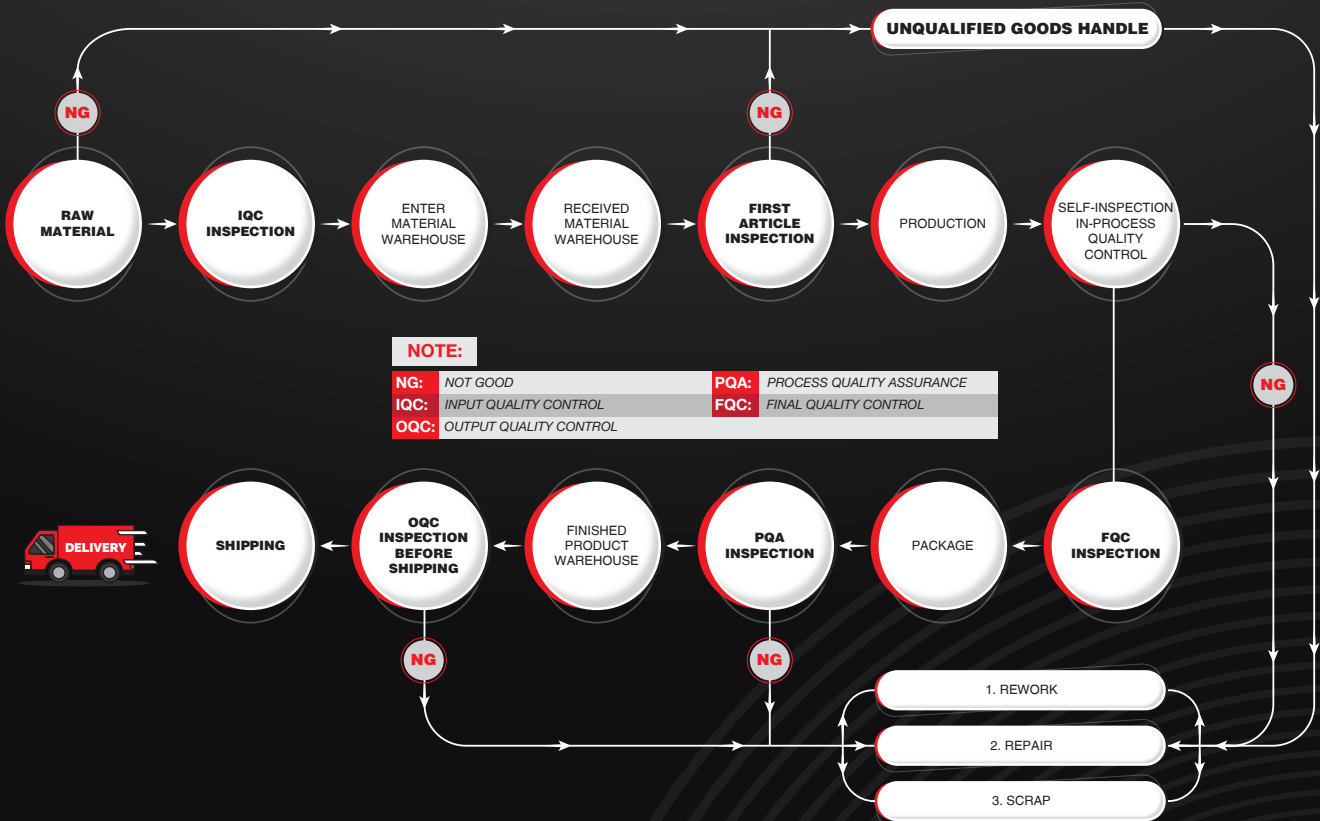

# TABLE OF CONTENT

## PRODUCT RANGE



# OLI FITNESS EQUIPMENT CATALOGUE

**STRENGTH MACHINES**

---

**PAGE. 08-27**

**MULTI-FUNCTION**

---

**PAGE. 28-31**

**STORAGE**

---

**PAGE. 32-35**

**BENCHES**

---

**PAGE. 36-39**

**RIGS & RACKS**

---

**PAGE. 40-45**

**ACCESSORIES**

---

**PAGE. 46-58**



# STRENGTH



# MACHINES

# STRENGTH MACHINES

Plate-loaded strength machines deliver an optimal balance of safety, control, and performance. Designed to support progressive strength development, they allow users to train with precision while maintaining correct biomechanics throughout each movement.

At QLI Fitness, our strength machines are engineered for durability, smooth load transfer, and consistent resistance. Built to meet the demands of commercial facilities and serious training environments, they provide a reliable platform for athletes and fitness professionals across all levels.

**Positioned machines clearly for commercial and professional use**



**QLI WEIGHT STACK SEATED  
DIP MACHINE**  
MODEL: QWSD065

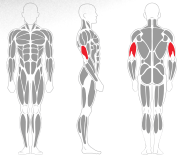

**DIMENSIONS**

| Length                | Width                | Height                | Net Weight          | Weight Capacity     |
|-----------------------|----------------------|-----------------------|---------------------|---------------------|
| 64 9/16"<br>(1685 mm) | 45 5/8"<br>(1159 mm) | 59 1/16"<br>(1500 mm) | 757 lbs<br>(344 kg) | 308 lbs<br>(140 kg) |

**QLI SEATED BACK  
ROW MACHINE**  
MODEL: QSBR46

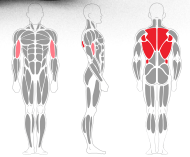

**DIMENSIONS**

| Length               | Width                | Height               | Net Weight            | Weight Capacity     |
|----------------------|----------------------|----------------------|-----------------------|---------------------|
| 45 7/8"<br>(1165 mm) | 56 1/2"<br>(1435 mm) | 59 1/4"<br>(1505 mm) | 609.4 lbs<br>(277 kg) | 253 lbs<br>(115 kg) |

**QLI LAT PULLDOWN SEATED  
ROW MACHINE**  
MODEL: QPSM083

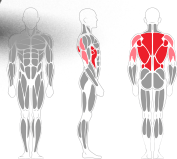

**DIMENSIONS**

| Length               | Width                | Height           | Net Weight            | Weight Capacity     |
|----------------------|----------------------|------------------|-----------------------|---------------------|
| 85 7/8"<br>(2182 mm) | 42 1/2"<br>(1079 mm) | 92"<br>(2337 mm) | 646.8 lbs<br>(294 kg) | 242 lbs<br>(110 kg) |

**QLI STANDING LATERAL  
RAISE MACHINE**  
MODEL: QSLR52

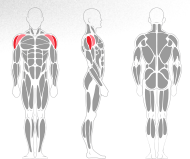

**DIMENSIONS**

| Length                | Width                | Height               | Net Weight          | Weight Capacity     |
|-----------------------|----------------------|----------------------|---------------------|---------------------|
| 52 1/16"<br>(1338 mm) | 29 3/16"<br>(741 mm) | 64 3/8"<br>(1642 mm) | 528 lbs<br>(240 kg) | 220 lbs<br>(100 kg) |

## QLI ADDUCTOR AND ABDUCTOR MACHINE

MODEL: QAAM01

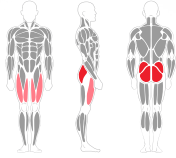

### DIMENSIONS

| Length    | Width     | Height    | Net Weight | Weight Capacity |
|-----------|-----------|-----------|------------|-----------------|
| 59 7/16"  | 49 7/16"  | 59 1/16"  | 704 lbs    | 264 lbs         |
| (1509 mm) | (1256 mm) | (1500 mm) | (320 kg)   | (120 kg)        |

## QLI DONKEY CALF RAISE MACHINE

MODEL: QDCRM70

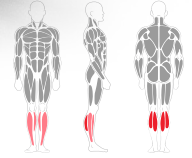

### DIMENSIONS

| Length    | Width     | Height    | Net Weight | Weight Capacity |
|-----------|-----------|-----------|------------|-----------------|
| 70 1/2"   | 30 13/16" | 67 5/16"  | 640 lbs    | 440 lbs         |
| (1790 mm) | (783 mm)  | (1710 mm) | (291 kg)   | (200 kg)        |

## QLI ASSISTED DIP CHIN MACHINE

MODEL: QADM193

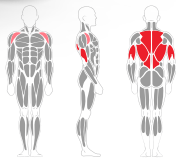

### DIMENSIONS

| Length    | Width     | Height    | Net Weight | Weight Capacity |
|-----------|-----------|-----------|------------|-----------------|
| 56 15/16" | 70 9/16"  | 88 7/16"  | 644.6 lbs  | 220 lbs         |
| (1446 mm) | (1792 mm) | (2247 mm) | (293 kg)   | (100 kg)        |

## QLI CHEST FLY MACHINE

MODEL: QCFM189

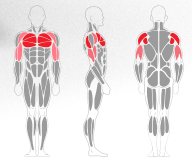

### DIMENSIONS

| Length    | Width     | Height    | Net Weight | Weight Capacity |
|-----------|-----------|-----------|------------|-----------------|
| 60 1/8"   | 62 3/16"  | 77 7/16"  | 594 lbs    | 220 lbs         |
| (1527 mm) | (1580 mm) | (1967 mm) | (270 kg)   | (100 kg)        |

## QLI FIXED LAT PULLDOWN MACHINE

MODEL: QFLP60

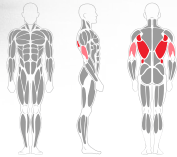

### DIMENSIONS

| Length               | Width                  | Height               | Net Weight            | Weight Capacity     |
|----------------------|------------------------|----------------------|-----------------------|---------------------|
| 62 3/8"<br>(1584 mm) | 55 15/16"<br>(1422 mm) | 78 1/4"<br>(1988 mm) | 641 lbs<br>(291.5 kg) | 220 lbs<br>(110 kg) |

## QLI GLUTE EXERCISE MACHINE

MODEL: QGEM91

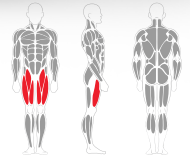

### DIMENSIONS

| Length                | Width                 | Height                | Net Weight          | Weight Capacity     |
|-----------------------|-----------------------|-----------------------|---------------------|---------------------|
| 82 7/16"<br>(2094 mm) | 57 3/16"<br>(1452 mm) | 67 3/16"<br>(1706 mm) | 961 lbs<br>(437 kg) | 440 lbs<br>(200 kg) |

## QLI DECLINE PRESS MACHINE

MODEL: QDPM060

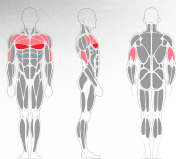

### DIMENSIONS

| Length               | Width                | Height                | Net Weight          | Weight Capacity     |
|----------------------|----------------------|-----------------------|---------------------|---------------------|
| 48 7/8"<br>(1242 mm) | 63 7/8"<br>(1623 mm) | 59 7/16"<br>(1510 mm) | 719 lbs<br>(327 kg) | 308 lbs<br>(140 kg) |

## QLI PRO-AXIS INCLINE CHEST PRESS

MODEL: QPAIP63

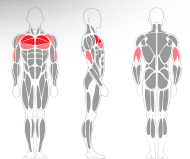

### DIMENSIONS

| Length               | Width                 | Height               | Net Weight               | Weight Capacity     |
|----------------------|-----------------------|----------------------|--------------------------|---------------------|
| 63 1/8"<br>(1604 mm) | 73 1/16"<br>(1855 mm) | 68 1/4"<br>(1733 mm) | 959.64 lbs<br>(436.2 kg) | 308 lbs<br>(140 kg) |

# QLI PRO-AXIS SHOULDER PRESS

MODEL: QPASP63

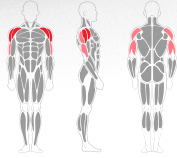

## DIMENSIONS

| Length                 | Width                 | Height               | Net Weight          | Weight Capacity     |
|------------------------|-----------------------|----------------------|---------------------|---------------------|
| 63 15/16"<br>(1625 mm) | 61 1/16"<br>(1551 mm) | 59 5/8"<br>(1515 mm) | 869 lbs<br>(395 kg) | 264 lbs<br>(120 kg) |

# QLI PRO-AXIS TRICEPS EXTENSION

MODEL: QPATE49

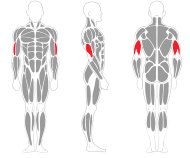

## DIMENSIONS

| Length               | Width                | Height               | Net Weight          | Weight Capacity     |
|----------------------|----------------------|----------------------|---------------------|---------------------|
| 49 5/8"<br>(1262 mm) | 50 7/8"<br>(1292 mm) | 59 1/4"<br>(1505 mm) | 693 lbs<br>(315 kg) | 242 lbs<br>(110 kg) |

# QLI PRO-AXIS DUAL PEC/FLY

MODEL: QPADP64

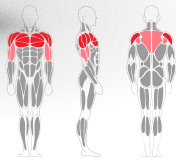

## DIMENSIONS

| Length               | Width                | Height               | Net Weight          | Weight Capacity     |
|----------------------|----------------------|----------------------|---------------------|---------------------|
| 64 7/8"<br>(1650 mm) | 48 1/4"<br>(1226 mm) | 80 1/8"<br>(2035 mm) | 660 lbs<br>(300 kg) | 264 lbs<br>(120 kg) |

# QLI PRO-AXIS PRONE LEG CURL

MODEL: QPAPC84

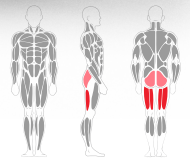

## DIMENSIONS

| Length               | Width                | Height               | Net Weight          | Weight Capacity     |
|----------------------|----------------------|----------------------|---------------------|---------------------|
| 79 3/8"<br>(2015 mm) | 43 7/8"<br>(1115 mm) | 59 1/2"<br>(1510 mm) | 695 lbs<br>(316 kg) | 264 lbs<br>(120 kg) |

**QLI PRO-AXIS SEATED ROW**  
MODEL: QPASR54

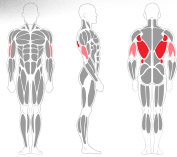

| DIMENSIONS            |                       |                      |                       |                     |
|-----------------------|-----------------------|----------------------|-----------------------|---------------------|
| Length                | Width                 | Height               | Net Weight            | Weight Capacity     |
| 54 3/16"<br>(1386 mm) | 55 1/16"<br>(1399 mm) | 74 1/8"<br>(1882 mm) | 846 lbs<br>(384.4 kg) | 308 lbs<br>(140 kg) |

**QLI PRO-AXIS TRICEPS DIP**  
MODEL: QPATD61

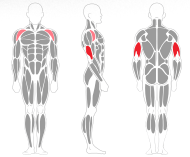

| DIMENSIONS           |                       |                       |                     |                     |
|----------------------|-----------------------|-----------------------|---------------------|---------------------|
| Length               | Width                 | Height                | Net Weight          | Weight Capacity     |
| 61 7/8"<br>(1572 mm) | 49 3/16"<br>(1250 mm) | 59 1/16"<br>(1500 mm) | 759 lbs<br>(345 kg) | 264 lbs<br>(120 kg) |

**QLI PRO-AXIS BICEPS CURL**  
MODEL: QPABC53

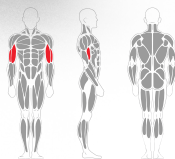

| DIMENSIONS           |                      |                       |                     |                     |
|----------------------|----------------------|-----------------------|---------------------|---------------------|
| Length               | Width                | Height                | Net Weight          | Weight Capacity     |
| 53 3/4"<br>(1365 mm) | 45 3/8"<br>(1152 mm) | 59 1/16"<br>(1507 mm) | 660 lbs<br>(300 kg) | 264 lbs<br>(120 kg) |

**QLI PRO-AXIS AB CRUNCH**  
MODEL: QPAC52

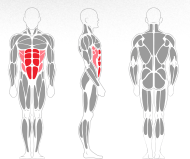

| DIMENSIONS           |                      |                       |                     |                     |
|----------------------|----------------------|-----------------------|---------------------|---------------------|
| Length               | Width                | Height                | Net Weight          | Weight Capacity     |
| 52 5/8"<br>(1336 mm) | 44 3/4"<br>(1137 mm) | 59 1/16"<br>(1500 mm) | 634 lbs<br>(288 kg) | 220 lbs<br>(100 kg) |

## QLI PRO-AXIS CHEST PRESS

MODEL: QPACP60

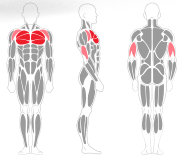

### DIMENSIONS

| Length               | Width                  | Height                | Net Weight             | Weight Capacity     |
|----------------------|------------------------|-----------------------|------------------------|---------------------|
| 65 3/4"<br>(1670 mm) | 60 13/16"<br>(1544 mm) | 77 7/16"<br>(1967 mm) | 1022 lbs<br>(464.5 kg) | 308 lbs<br>(140 kg) |

## QLI PRO-AXIS CALF RAISE

MODEL: QPACR65

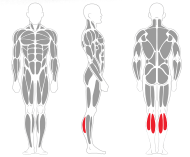

### DIMENSIONS

| Length                | Width                | Height               | Net Weight          | Weight Capacity     |
|-----------------------|----------------------|----------------------|---------------------|---------------------|
| 64 7/16"<br>(1636 mm) | 49 3/4"<br>(1265 mm) | 59 1/4"<br>(1504 mm) | 796 lbs<br>(362 kg) | 330 lbs<br>(150 kg) |

## QLI PRO-AXIS SEATED LEG CURL

MODEL: QPALC49

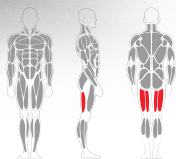

### DIMENSIONS

| Length                 | Width            | Height                | Net Weight          | Weight Capacity     |
|------------------------|------------------|-----------------------|---------------------|---------------------|
| 49 15/16"<br>(1269 mm) | 49"<br>(1245 mm) | 59 7/16"<br>(1510 mm) | 781 lbs<br>(355 kg) | 264 lbs<br>(120 kg) |

## QLI PRO-AXIS LEG EXTENSION

MODEL: QPALE47

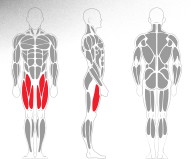

### DIMENSIONS

| Length               | Width                | Height               | Net Weight          | Weight Capacity     |
|----------------------|----------------------|----------------------|---------------------|---------------------|
| 47 7/8"<br>(1215 mm) | 46 7/8"<br>(1170 mm) | 59 7/8"<br>(1505 mm) | 721 lbs<br>(322 kg) | 264 lbs<br>(120 kg) |

## QLI PRO-AXIS LATERAL RAISE

MODEL: QPALR62

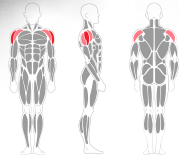

### DIMENSIONS

| Length                | Width                | Height                | Net Weight          | Weight Capacity     |
|-----------------------|----------------------|-----------------------|---------------------|---------------------|
| 62 3/16"<br>(1579 mm) | 47 1/4"<br>(1200 mm) | 59 7/16"<br>(1510 mm) | 748 lbs<br>(340 kg) | 264 lbs<br>(120 kg) |

## QLI PRO-AXIS ROW MACHINE

MODEL: QPARM63

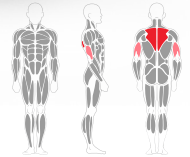

### DIMENSIONS

| Length                 | Width                | Height                | Net Weight          | Weight Capacity     |
|------------------------|----------------------|-----------------------|---------------------|---------------------|
| 63 15/16"<br>(1624 mm) | 43 3/4"<br>(1112 mm) | 59 1/16"<br>(1500 mm) | 726 lbs<br>(330 kg) | 264 lbs<br>(120 kg) |

## QLI PRO-AXIS SEATED LEG PRESS

MODEL: QPALP74

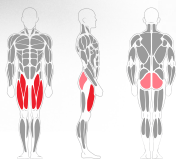

### DIMENSIONS

| Length               | Width                 | Height               | Net Weight           | Weight Capacity     |
|----------------------|-----------------------|----------------------|----------------------|---------------------|
| 74 3/4"<br>(1899 mm) | 55 7/16"<br>(1408 mm) | 71 1/4"<br>(1809 mm) | 1181 lbs<br>(537 kg) | 484 lbs<br>(220 kg) |

## QLI WIDE SHOULDER PRESS MACHINE

MODEL: QWSPM062



### DIMENSIONS

| Length                | Width                | Height                 | Net Weight          | Weight Capacity     |
|-----------------------|----------------------|------------------------|---------------------|---------------------|
| 62 5/16"<br>(1583 mm) | 56 3/4"<br>(1441 mm) | 53 13/16"<br>(1363 mm) | 671 lbs<br>(305 kg) | 220 lbs<br>(100 kg) |

## QLI 45 DEGREE LEG PRESS

MODEL: QLP045

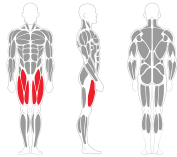

### DIMENSIONS

| Length            | Width             | Height            | Net Weight       | Weight Capacity  |
|-------------------|-------------------|-------------------|------------------|------------------|
| 85 1/4" (2160 mm) | 72 1/4" (1852 mm) | 54 7/8" (1394 mm) | 440 lbs (200 kg) | 990 lbs (450 kg) |

## QLI WIDE CHEST PRESS

MODEL: QWCP072

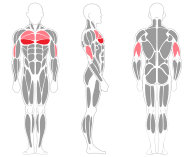

### DIMENSIONS

| Length            | Width             | Height            | Net Weight       | Weight Capacity  |
|-------------------|-------------------|-------------------|------------------|------------------|
| 73 1/4" (1860 mm) | 49 1/8" (1247 mm) | 70 1/8" (1802 mm) | 319 lbs (145 kg) | 440 lbs (200 kg) |

## QLI PLATE LOADED SEATED DIP MACHINE

MODEL: QPSD058



### DIMENSIONS

| Length            | Width             | Height            | Net Weight       | Weight Capacity  |
|-------------------|-------------------|-------------------|------------------|------------------|
| 61 1/4" (1570 mm) | 59 1/4" (1520 mm) | 35 9/16" (903 mm) | 308 lbs (140 kg) | 440 lbs (200 kg) |

## QLI SHOULDER PRESS MACHINE

MODEL: QSPM070



### DIMENSIONS

| Length             | Width                               | Height            | Net Weight           | Weight Capacity  |
|--------------------|-------------------------------------|-------------------|----------------------|------------------|
| 68 7/16" (1738 mm) | 54 1/16" - 55 1/4" (1373 - 1418 mm) | 59 1/8" (1502 mm) | 304.9 lbs (138.6 kg) | 440 lbs (200 kg) |

## QLI LEG CURL BENCH

MODEL: QLCB330

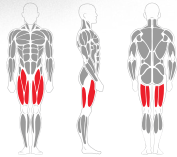

### DIMENSIONS

| Length    | Width    | Height    | Net Weight | Weight Capacity |
|-----------|----------|-----------|------------|-----------------|
| 75 15/16" | 33 3/8"  | 29 15/16" | 144 lbs    | 308 lbs         |
| (1929 mm) | (841 mm) | (760 mm)  | (65.5 kg)  | (140 kg)        |

## QLI SEATED ROW MACHINE

MODEL: QSRM060

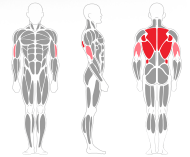

### DIMENSIONS

| Length    | Width     | Height    | Net Weight | Weight Capacity |
|-----------|-----------|-----------|------------|-----------------|
| 64 5/16"  | 55 15/16" | 51 7/16"  | 297 lbs    | 440 lbs         |
| (1634 mm) | (1421 mm) | (1306 mm) | (135 kg)   | (200 kg)        |

## QLI PLATE LOADED PULLOVER

MODEL: QPLP083

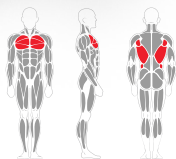

### DIMENSIONS

| Length    | Width     | Height    | Net Weight | Weight Capacity |
|-----------|-----------|-----------|------------|-----------------|
| 84 3/16"  | 59 5/8"   | 55 15/16" | 500 lbs    | 264 lbs         |
| (2139 mm) | (1514 mm) | (1422 mm) | (227 kg)   | (120 kg)        |

## QLI PURE CHEST PRESS

MODEL: QPCP073

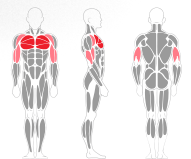

### DIMENSIONS

| Length    | Width     | Height    | Net Weight | Weight Capacity |
|-----------|-----------|-----------|------------|-----------------|
| 75 1/4"   | 49 5/16"  | 70"       | 330 lbs    | 440 lbs         |
| (1912 mm) | (1253 mm) | (1778 mm) | (150 kg)   | (200 kg)        |

## QLI AB CRUNCH MACHINE

MODEL: QCM01

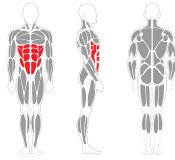

### DIMENSIONS

| Length               | Width                | Height               | Net Weight          | Weight Capacity     |
|----------------------|----------------------|----------------------|---------------------|---------------------|
| 48 3/4"<br>(1238 mm) | 53 1/8"<br>(1350 mm) | 60 1/8"<br>(1526 mm) | 275 lbs<br>(125 kg) | 264 lbs<br>(120 kg) |

## QLI PLATE LOADED CHEST PRESS

MODEL: QCP660

MODEL: QCP660

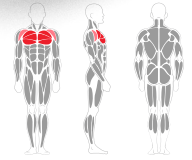

### DIMENSIONS

| Length               | Width                 | Height               | Net Weight         | Weight Capacity     |
|----------------------|-----------------------|----------------------|--------------------|---------------------|
| 73 1/2"<br>(1867 mm) | 58 7/16"<br>(1484 mm) | 51 1/8"<br>(1298 mm) | 211 lbs<br>(96 kg) | 440 lbs<br>(200 kg) |

## QLI FREE STANDING J SQUAT – SINGLE SIDED

MODEL: QFSS058



### DIMENSIONS

| Length               | Width               | Height              | Net Weight        | Weight Capacity     |
|----------------------|---------------------|---------------------|-------------------|---------------------|
| 57 5/8"<br>(1463 mm) | 33 5/8"<br>(854 mm) | 23 3/8"<br>(594 mm) | 62 lbs<br>(28 kg) | 880 lbs<br>(400 kg) |

## QLI FREE STANDING J SQUAT – DOUBLE SIDED

MODEL: QFDS107



### DIMENSIONS

| Length                  | Width               | Height              | Net Weight         | Weight Capacity     |
|-------------------------|---------------------|---------------------|--------------------|---------------------|
| 107 15/16"<br>(2742 mm) | 30 5/8"<br>(778 mm) | 23 3/8"<br>(594 mm) | 158 lbs<br>(72 kg) | 880 lbs<br>(400 kg) |

**QLI STANDING LEG  
CURL-PLATE LOAD**  
MODEL: QSLC038

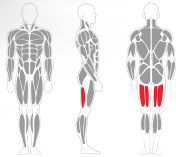

**DIMENSIONS**

| Length               | Width                | Height               | Net Weight         | Weight Capacity     |
|----------------------|----------------------|----------------------|--------------------|---------------------|
| 44 1/4"<br>(1125 mm) | 50 3/8"<br>(1280 mm) | 49 5/8"<br>(1260 mm) | 184 lbs<br>(84 kg) | 330 lbs<br>(150 kg) |

**QLI BELT SQUAT**  
MODEL: QBQ090



**DIMENSIONS**

| Length                | Width                  | Height                | Net Weight          | Weight Capacity  |
|-----------------------|------------------------|-----------------------|---------------------|--|
| 89 5/16"<br>(2268 mm) | 55 11/16"<br>(1415 mm) | 43 3/16"<br>(1097 mm) | 231 lbs<br>(105 kg) | 550 lbs (250 kg)/Per side<br>1100 lbs (500 kg)/Both Side |

**QLI LAT PULL ROW PLATE  
MACHINE**  
MODEL: QLPRM93

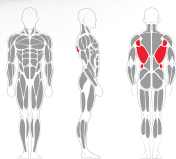

**DIMENSIONS**

| Length                | Width                  | Height               | Net Weight          | Weight Capacity     |
|-----------------------|------------------------|----------------------|---------------------|---------------------|
| 93 7/16"<br>(2374 mm) | 59 13/16"<br>(1520 mm) | 89 3/8"<br>(2264 mm) | 455 lbs<br>(207 kg) | 550 lbs<br>(250 kg) |

**QLI LEG RAISE & DIP**  
MODEL: QLRD065

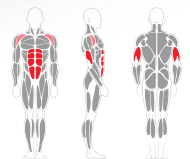

**DIMENSIONS**

| Length               | Width                | Height                 | Net Weight             |
|----------------------|----------------------|------------------------|------------------------|
| 44 7/8"<br>(1140 mm) | 33 5/16"<br>(846 mm) | 59 13/16"<br>(1519 mm) | 144.5 lbs<br>(65.7 kg) |

## QLI STRETCH TRAINER

MODEL: QST060



### DIMENSIONS

| Length                | Width                 | Height                 | Net Weight         |
|-----------------------|-----------------------|------------------------|--------------------|
| 61 5/16"<br>(1557 mm) | 27 13/16"<br>(706 mm) | 46 13/16"<br>(1189 mm) | 108 lbs<br>(49 kg) |

## QLI PREACHER CURL SITTING

MODEL: QPCS042

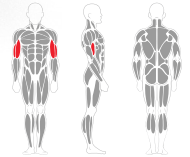

### DIMENSIONS

| Length                | Width                 | Height               | Net Weight         |
|-----------------------|-----------------------|----------------------|--------------------|
| 42 1/16"<br>(1068 mm) | 29 15/16"<br>(760 mm) | 36 7/16"<br>(925 mm) | 114 lbs<br>(52 kg) |

## QLI PENDULUM SQUAT M2

MODEL: QPSM2

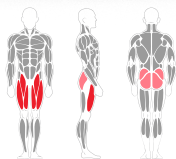

### DIMENSIONS

| Length               | Width                 | Height                 | Net Weight            | Weight Capacity     |
|----------------------|-----------------------|------------------------|-----------------------|---------------------|
| 90 1/2"<br>(2298 mm) | 63 7/16"<br>(1611 mm) | 67 13/16"<br>(1720 mm) | 457.6 lbs<br>(208 kg) | 660 lbs<br>(300 kg) |

## QLI HIP PRESS

MODEL: QHP092

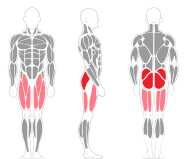

### DIMENSIONS

| Length                 | Width                 | Height           | Net Weight           | Weight Capacity       |
|------------------------|-----------------------|------------------|----------------------|-----------------------|
| 92 15/16"<br>(2362 mm) | 65 1/16"<br>(1652 mm) | 67"<br>(1702 mm) | 1320 lbs<br>(600 kg) | 608 lbs<br>(276.4 kg) |

## QLI PURE LINEAR LEG PRESS

MODEL: QPLP105

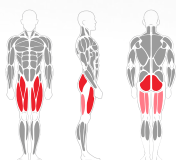

### DIMENSIONS

| Length                  | Width                  | Height               | Net Weight          | Weight Capacity     |
|-------------------------|------------------------|----------------------|---------------------|---------------------|
| 102 13/16"<br>(2611 mm) | 62 15/16"<br>(1600 mm) | 50 1/4"<br>(1276 mm) | 453 lbs<br>(206 kg) | 990 lbs<br>(450 kg) |

## QLI ADJUSTABLE HACK SQUAT MACHINE

MODEL: QAHS100

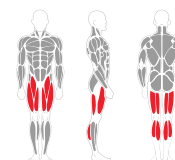

### DIMENSIONS

| Length                 | Width                 | Height                | Net Weight          | Weight Capacity     |
|------------------------|-----------------------|-----------------------|---------------------|---------------------|
| 100 9/16"<br>(2555 mm) | 59 7/16"<br>(1510 mm) | 56 9/16"<br>(1436 mm) | 770 lbs<br>(350 kg) | 475 lbs<br>(216 kg) |

## QLI VERTICAL LEG PRESS

MODEL: QVLP070

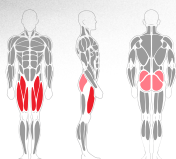

### DIMENSIONS

| Length                 | Width                | Height                 | Net Weight          | Weight Capacity     |
|------------------------|----------------------|------------------------|---------------------|---------------------|
| 73 13/16"<br>(1871 mm) | 70 1/2"<br>(1780 mm) | 84 13/16"<br>(2155 mm) | 482 lbs<br>(219 kg) | 660 lbs<br>(300 kg) |

## QLI INCLINE ROW MACHINE

MODEL: QIRM92

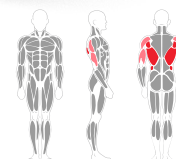

### DIMENSIONS

| Length               | Width                | Height           | Net Weight          | Weight Capacity     |
|----------------------|----------------------|------------------|---------------------|---------------------|
| 84 7/8"<br>(2156 mm) | 72 1/2"<br>(1830 mm) | 56"<br>(1423 mm) | 493 lbs<br>(224 kg) | 660 lbs<br>(300 kg) |

## QLI PLATE LOADED INCLINE CHEST PRESS

MODEL: QPCP88

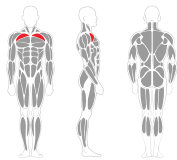

### DIMENSIONS

| Length                | Width                 | Height                | Net Weight          | Weight Capacity     |
|-----------------------|-----------------------|-----------------------|---------------------|---------------------|
| 89 7/16"<br>(2272 mm) | 78 3/16"<br>(1986 mm) | 58 9/16"<br>(1487 mm) | 539 lbs<br>(245 kg) | 660 lbs<br>(300 kg) |

## QLI ADJUSTABLE LAT PULLDOWN MACHINE

MODEL: QALPM93

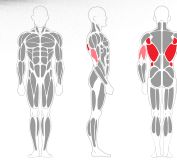

### DIMENSIONS

| Length                | Width                  | Height               | Net Weight          | Weight Capacity     |
|-----------------------|------------------------|----------------------|---------------------|---------------------|
| 93 7/16"<br>(2374 mm) | 59 13/16"<br>(1520 mm) | 89 1/8"<br>(2263 mm) | 478 lbs<br>(217 kg) | 550 lbs<br>(250 kg) |

## QLI BICEP CURL MACHINE

MODEL: QBCM060



### DIMENSIONS

| Length                | Width                 | Height              | Net Weight          | Weight Capacity     |
|-----------------------|-----------------------|---------------------|---------------------|---------------------|
| 54 1/16"<br>(1373 mm) | 45 3/16"<br>(1148 mm) | 38 1/8"<br>(968 mm) | 240 lbs<br>(109 kg) | 352 lbs<br>(160 kg) |

## QLI HIP THRUST MACHINE

MODEL: QHTM050

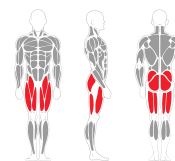

### DIMENSIONS

| Length                | Width                | Height                | Net Weight          | Weight Capacity     |
|-----------------------|----------------------|-----------------------|---------------------|---------------------|
| 73 7/16"<br>(1865 mm) | 53 7/8"<br>(1368 mm) | 44 5/16"<br>(1126 mm) | 308 lbs<br>(140 kg) | 264 lbs<br>(120 kg) |

## QLI PRONE LEG CURL

MODEL: QPLC078

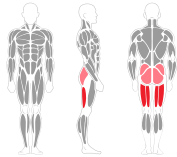

### DIMENSIONS

| Length               | Width                | Height              | Net Weight         | Weight Capacity     |
|----------------------|----------------------|---------------------|--------------------|---------------------|
| 82 3/8"<br>(2093 mm) | 44 1/2"<br>(1130 mm) | 33 3/4"<br>(857 mm) | 207 lbs<br>(94 kg) | 396 lbs<br>(180 kg) |

## QLI ADJUSTABLE SHOULDER PRESS MACHINE

MODEL: QASP63

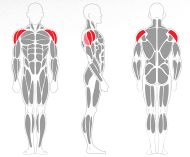

### DIMENSIONS

| Length                | Width                 | Height               | Net Weight          | Weight Capacity     |
|-----------------------|-----------------------|----------------------|---------------------|---------------------|
| 64 7/16"<br>(1636 mm) | 78 1/16"<br>(1982 mm) | 59 3/8"<br>(1508 mm) | 548 lbs<br>(249 kg) | 660 lbs<br>(300 kg) |

## QLI PLATE LOADED T- BAR ROW MACHINE

MODEL: QPTBR86

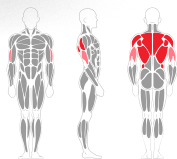

### DIMENSIONS

| Length               | Width                 | Height               | Net Weight         | Weight Capacity     |
|----------------------|-----------------------|----------------------|--------------------|---------------------|
| 86 1/8"<br>(2186 mm) | 49 1/16"<br>(1246 mm) | 49 1/4"<br>(1252 mm) | 216 lbs<br>(98 kg) | 396 lbs<br>(180 kg) |

## QLI ADJUSTABLE SEATED ROW MACHINE

MODEL: QASR62

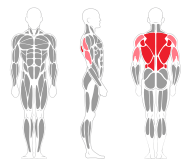

### DIMENSIONS

| Length                 | Width                 | Height                 | Net Weight          | Weight Capacity     |
|------------------------|-----------------------|------------------------|---------------------|---------------------|
| 60 15/16"<br>(1549 mm) | 57 3/16"<br>(1452 mm) | 48 13/16"<br>(1240 mm) | 660 lbs<br>(300 kg) | 370 lbs<br>(168 kg) |

## QLI ADJUSTABLE LEG EXTENSION MACHINE

MODEL: QALE61

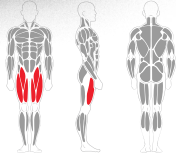

### DIMENSIONS

| Length           | Width                 | Height                 | Net Weight          | Weight Capacity     |
|------------------|-----------------------|------------------------|---------------------|---------------------|
| 61"<br>(1550 mm) | 50 3/16"<br>(1275 mm) | 45 15/16"<br>(1167 mm) | 363 lbs<br>(165 kg) | 440 lbs<br>(200 kg) |

## QLI STANDING LEG CURL

MODEL: QSLC064

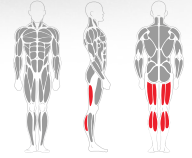

### DIMENSIONS

| Length                | Width                 | Height               | Net Weight          | Weight Capacity     |
|-----------------------|-----------------------|----------------------|---------------------|---------------------|
| 55 3/16"<br>(1402 mm) | 51 3/16"<br>(1300 mm) | 48 1/8"<br>(1223 mm) | 266 lbs<br>(121 kg) | 220 lbs<br>(100 kg) |

## QLI LEG EXTENSION

MODEL: QLE059

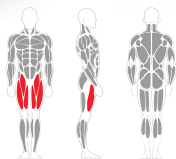

### DIMENSIONS

| Length               | Width                | Height                | Net Weight          | Weight Capacity     |
|----------------------|----------------------|-----------------------|---------------------|---------------------|
| 49 1/4"<br>(1251 mm) | 66 3/4"<br>(1695 mm) | 53 7/16"<br>(1358 mm) | 304 lbs<br>(138 kg) | 660 lbs<br>(300 kg) |

## QLI INCLINE CHEST PRESS

MODEL: QICP080

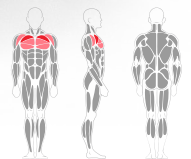

### DIMENSIONS

| Length               | Width                | Height               | Net Weight            | Weight Capacity     |
|----------------------|----------------------|----------------------|-----------------------|---------------------|
| 77 1/4"<br>(1962 mm) | 43 3/8"<br>(1101 mm) | 73 3/8"<br>(1857 mm) | 312.4 lbs<br>(142 kg) | 440 lbs<br>(200 kg) |

## QLI PLATE LOADED LEVER ROW

MODEL: QPLR70

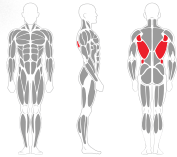

### DIMENSIONS

| Length                 | Width                | Height                 | Net Weight          | Weight Capacity     |
|------------------------|----------------------|------------------------|---------------------|---------------------|
| 67 13/16"<br>(1722 mm) | 60 1/4"<br>(1530 mm) | 47 11/16"<br>(1211 mm) | 250 lbs<br>(114 kg) | 440 lbs<br>(200 kg) |

## QLI SEATED CALF RAISE MACHINE

MODEL: QSCR075

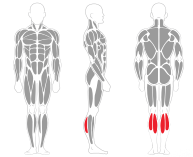

### DIMENSIONS

| Length                | Width                 | Height              | Net Weight         | Weight Capacity     |
|-----------------------|-----------------------|---------------------|--------------------|---------------------|
| 76 9/16"<br>(1945 mm) | 42 5/16"<br>(1074 mm) | 37 1/8"<br>(943 mm) | 189 lbs<br>(86 kg) | 484 lbs<br>(220 kg) |

## QLI STANDING ABDUCTOR

MODEL: QSA074

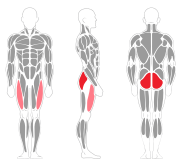

### DIMENSIONS

| Length                 | Width                | Height               | Net Weight          | Weight Capacity     |
|------------------------|----------------------|----------------------|---------------------|---------------------|
| 73 15/16"<br>(1878 mm) | 42 1/8"<br>(1070 mm) | 60 1/4"<br>(1530 mm) | 301 lbs<br>(137 kg) | 484 lbs<br>(220 kg) |

## QLI CHEST PRESS MACHINE

MODEL: QCP78

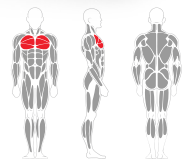

### DIMENSIONS

| Length               | Width                  | Height              | Net Weight          | Weight Capacity     |
|----------------------|------------------------|---------------------|---------------------|---------------------|
| 76 5/8"<br>(1946 mm) | 75 13/16"<br>(1925 mm) | 39 1/8"<br>(993 mm) | 372 lbs<br>(169 kg) | 550 lbs<br>(250 kg) |

## QLI LAT PULLDOWN – LOW ROW

MODEL: QPLR050

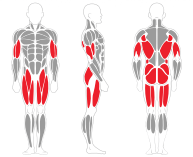
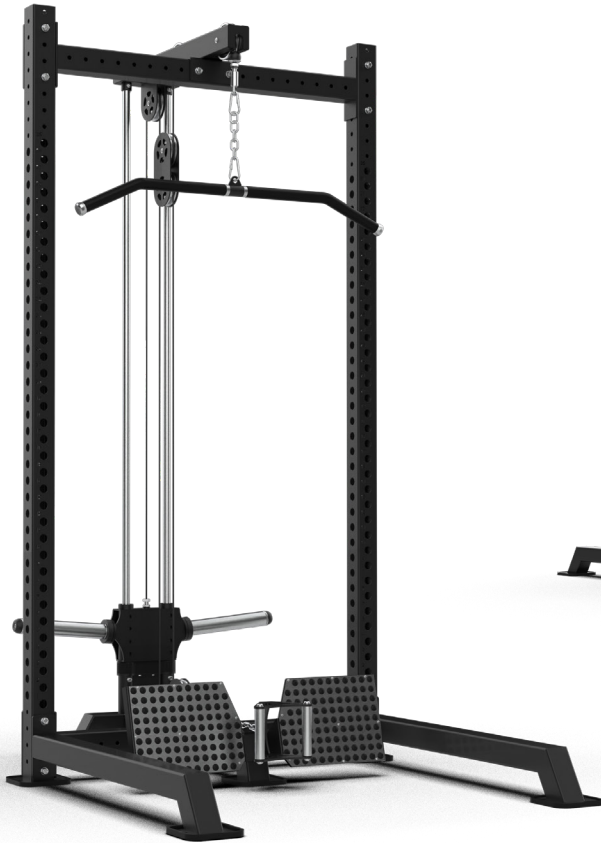

### DIMENSIONS

| Length   | Width  | Height   | Net Weight            | Weight Capacity     |
|--|--|--|-----------------------|---------------------|
| 66 1 <sup>1</sup> / <sub>16</sub> "<br>(1694 mm) | 52 1 <sup>1</sup> / <sub>16</sub> "<br>(1322 mm) | 92 1 <sup>5</sup> / <sub>16</sub> "<br>(2360 mm) | 316.8 lbs<br>(144 kg) | 550 lbs<br>(250 kg) |

## QLI LAT PULLDOWN

MODEL: QLP01

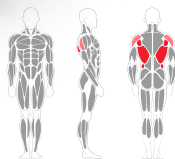

### DIMENSIONS

| Length  | Width  | Height  | Net Weight          | Weight Capacity     |
|---|--|---|---------------------|---------------------|
| 77 1 <sup>1</sup> / <sub>2</sub> "<br>(1968 mm) | 59 5 <sup>1</sup> / <sub>16</sub> "<br>(1507 mm) | 77 3 <sup>1</sup> / <sub>8</sub> "<br>(1966 mm) | 338 lbs<br>(154 kg) | 440 lbs<br>(200 kg) |

## QLI T-BAR ROW

MODEL: QTBR070

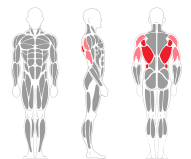

### DIMENSIONS

| Length  | Width   | Height  | Net Weight         | Weight Capacity     |
|---|---|---|--------------------|---------------------|
| 69 3 <sup>1</sup> / <sub>4</sub> "<br>(1771 mm) | 48 1 <sup>1</sup> / <sub>8</sub> "<br>(1222 mm) | 26 1 <sup>1</sup> / <sub>16</sub> "<br>(662 mm) | 216 lbs<br>(98 kg) | 440 lbs<br>(200 kg) |

# MULTI FUNCTION

Maximise training efficiency and floor space with our versatile multi-function systems. Designed as all-in-one strength solutions, these units enable a wide range of full-body exercises within a compact footprint.

With advanced mechanical design and adaptable configurations, users can perform movements such as squats, presses, rows, and functional training variations - supporting strength development, muscle conditioning, and overall performance in one integrated system.

**Strengthened appeal for studios and commercial facilities**





## QLI DUAL CABLE CROSSOVER MACHINE

MODEL: QDCM58



### DIMENSIONS

| Length        | Width             | Height             | Net Weight       | Weight Capacity  |
|---------------|-------------------|--------------------|------------------|------------------|
| 59" (1499 mm) | 47 1/2" (1206 mm) | 67 7/16" (1713 mm) | 880 lbs (400 kg) | 462 lbs (210 kg) |

## QLI FOLD-AWAY STRENGTH TRAINER

MODEL: QFST085



### DIMENSIONS

| Length                             | Width                              | Height             | Net Weight       | Weight Capacity  |
|------------------------------------|------------------------------------|--------------------|------------------|------------------|
| 45 7/8" - 54 1/2" (1165 - 1385 mm) | 53 3/4" - 71 1/8" (1352 - 1807 mm) | 89 7/16" (2272 mm) | 829 lbs (377 kg) | 528 lbs (240 kg) |

## QLI MULTI-FUNCTIONAL RACK

MODEL: QMFR81



### DIMENSIONS

| Length              | Width          | Height            | Net Weight        | Weight Capacity  |
|---------------------|----------------|-------------------|-------------------|------------------|
| 79 13/16" (2024 mm) | 150" (3810 mm) | 96 3/4" (2458 mm) | 1322 lbs (601 kg) | 440 lbs (200 kg) |

## QLI MULTI-FUNCTION POWER CAGE

MODEL: QMPC125



### DIMENSIONS

| Length              | Width                | Height             | Net Weight        | Weight Capacity               |
|---------------------|----------------------|--------------------|-------------------|-------------------------------|
| 125 9/16" (3189 mm) | 119 13/16" (3040 mm) | 106 3/8" (2696 mm) | 2046 lbs (930 kg) | 485/2 cluster (220/2 cluster) |

## QLI MULTI FLEX

MODEL: QMF300



### DIMENSIONS

| Length               | Width                | Height                | Net Weight          | Weight Capacity     |
|----------------------|----------------------|-----------------------|---------------------|---------------------|
| 71 1/4"<br>(1810 mm) | 61 1/2"<br>(1551 mm) | 34 13/16"<br>(885 mm) | 299 lbs<br>(136 kg) | 660 lbs<br>(300 kg) |

## QLI MULTI-FUNCTION HOME GYM

MODEL: QMHG206



### DIMENSIONS

| Length                | Width            | Height                 | Net Weight          | Weight Capacity    |
|-----------------------|------------------|------------------------|---------------------|--------------------|
| 80 3/16"<br>(2046 mm) | 44"<br>(1118 mm) | 83 13/16"<br>(2133 mm) | 748 lbs<br>(340 kg) | 176 lbs<br>(80 kg) |

## QLI MULTI CABLE CROSSOVER MACHINE

MODEL: QMCM182



### DIMENSIONS

| Length                | Width                  | Height               | Net Weight           | Weight Capacity                   |
|-----------------------|------------------------|----------------------|----------------------|-----------------------------------|
| 176 1/4"<br>(4477 mm) | 96 13/16"<br>(2459 mm) | 96 3/4"<br>(2457 mm) | 2090 lbs<br>(950 kg) | 1058/4 cluster<br>(480/4 cluster) |

## QLI FUNCTIONAL TRAINER MACHINE

MODEL: QFTM77



### DIMENSIONS

| Length               | Width                 | Height               | Net Weight           | Weight Capacity     |
|----------------------|-----------------------|----------------------|----------------------|---------------------|
| 74 3/4"<br>(1899 mm) | 55 7/16"<br>(1408 mm) | 71 1/4"<br>(1809 mm) | 1181 lbs<br>(537 kg) | 528 lbs<br>(240 kg) |

# STORAGE

Efficient storage is fundamental to a safe, organised, and professional training environment. Our storage solutions are designed to keep weights, bars, and accessories securely arranged and easily accessible.

Built for durability and daily commercial use, QLI Fitness storage systems help maintain a clean, clutter-free gym floor - improving workflow, safety, and the overall user experience while reinforcing a professional facility image.

**Shifted focus from “essential” to operational excellence**



# STOPSPACE



## QLI DISC & DUMBBELL RACK

MODEL: QDR144



### DIMENSIONS

| Length                | Width                 | Height               | Net Weight          | Weight Capacity      |
|-----------------------|-----------------------|----------------------|---------------------|----------------------|
| 144 1/8"<br>(3660 mm) | 26 13/16"<br>(681 mm) | 41 3/4"<br>(1048 mm) | 341 lbs<br>(155 kg) | 1100 lbs<br>(500 kg) |

## QLI DUMBBELL STORAGE RACK

MODEL: QDSR84



### DIMENSIONS

| Length               | Width               | Height                | Net Weight         | Weight Capacity      |
|----------------------|---------------------|-----------------------|--------------------|----------------------|
| 58 7/8"<br>(1496 mm) | 27 1/2"<br>(699 mm) | 43 9/16"<br>(1106 mm) | 158 lbs<br>(72 kg) | 1469 lbs<br>(680 kg) |

## QLI BARBELL STORAGE RACK

MODEL: QBSR92

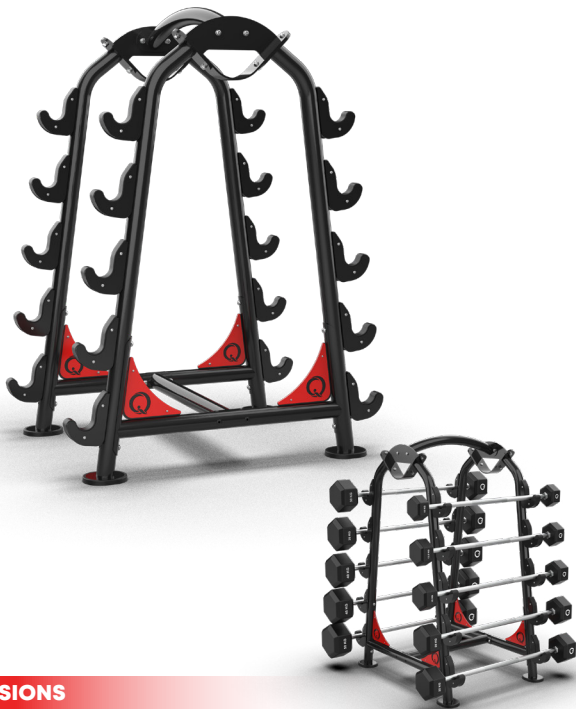

### DIMENSIONS

| Length                | Width               | Height               | Net Weight         | Weight Capacity     |
|-----------------------|---------------------|----------------------|--------------------|---------------------|
| 46 5/16"<br>(1176 mm) | 32 1/2"<br>(826 mm) | 61 3/4"<br>(1568 mm) | 132 lbs<br>(60 kg) | 660 lbs<br>(300 kg) |

## QLI WEIGHT PLATE STORAGE RACK

MODEL: QWPR37



### DIMENSIONS

| Length               | Width               | Height                 | Net Weight        | Weight Capacity      |
|----------------------|---------------------|------------------------|-------------------|----------------------|
| 37 9/16"<br>(954 mm) | 26 3/4"<br>(680 mm) | 54 15/16"<br>(1396 mm) | 79 lbs<br>(36 kg) | 1430 lbs<br>(650 kg) |

**QLI KETTLEBELL  
STORAGE RACK**  
MODEL: QKSR54



**DIMENSIONS**

| Length           | Width               | Height          | Net Weight           | Weight Capacity     |
|------------------|---------------------|-----------------|----------------------|---------------------|
| 67"<br>(1702 mm) | 27 1/2"<br>(699 mm) | 39"<br>(991 mm) | 148 lbs<br>(67.4 kg) | 825 lbs<br>(375 kg) |

**QLI OLYMPIC WEIGHT TREE**  
MODEL: QWT400



**DIMENSIONS**

| Length               | Width               | Height               | Net Weight        | Weight Capacity     |
|----------------------|---------------------|----------------------|-------------------|---------------------|
| 35 7/16"<br>(900 mm) | 27 3/8"<br>(695 mm) | 52 3/4"<br>(1340 mm) | 75 lbs<br>(34 kg) | 880 lbs<br>(400 kg) |



# BENCHES

Engineered for stability, comfort, and performance, our benches are designed to support a wide range of strength training and bodybuilding applications.

Whether used in commercial gyms, training studios, or premium home setups, QLI Fitness benches deliver professional-grade construction and reliable support - helping users train with confidence and progress to the next level.

**Clarified usage across commercial and home environments**



# BENEFITS



## QLI ADJUSTABLE BENCH

MODEL: QAB01



### DIMENSIONS

| Length               | Width           | Height               | Net Weight         |
|----------------------|-----------------|----------------------|--------------------|
| 57 1/2"<br>(1460 mm) | 22"<br>(559 mm) | 17 5/16"<br>(440 mm) | 112 lbs<br>(51 kg) |

## QLI ADJUSTABLE BENCH

MODEL: QAB03



### DIMENSIONS

| Length               | Width                | Height              | Net Weight        |
|----------------------|----------------------|---------------------|-------------------|
| 53 1/8"<br>(1350 mm) | 25 3/16"<br>(640 mm) | 17 1/2"<br>(444 mm) | 90 lbs<br>(41 kg) |

## QLI BACK EXTENSION

MODEL: QBE030

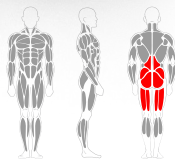

### DIMENSIONS

| Length                | Width               | Height                | Net Weight         |
|-----------------------|---------------------|-----------------------|--------------------|
| 49 9/16"<br>(1259 mm) | 33 1/8"<br>(842 mm) | 40 9/16"<br>(1031 mm) | 101 lbs<br>(46 kg) |

## QLI BENCH PRESS FRAME

MODEL: QBPF056

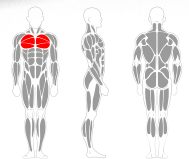

### DIMENSIONS

| Length                | Width                 | Height               | Net Weight            |
|-----------------------|-----------------------|----------------------|-----------------------|
| 49 3/16"<br>(1250 mm) | 52 1/16"<br>(1322 mm) | 56 1/2"<br>(1435 mm) | 283.8 lbs<br>(129 kg) |

# QLI MULTI BENCH PRESS

MODEL: QMP450

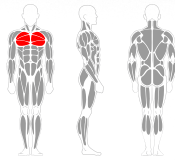

## DIMENSIONS

| Length           | Width                | Height                | Net Weight          | Weight Capacity     |
|------------------|----------------------|-----------------------|---------------------|---------------------|
| 75"<br>(1905 mm) | 86 5/8"<br>(2200 mm) | 63 7/16"<br>(1612 mm) | 224 lbs<br>(102 kg) | 880 lbs<br>(400 kg) |



# RIGS & RACKS

Our rigs and racks are built to form the backbone of high-performance training spaces. Designed for strength, versatility, and modular expansion, they support a wide range of compound lifts and functional training applications.

Engineered for structural integrity and long-term durability, QLI Fitness rigs and racks help create organised, efficient, and scalable training environments suited to commercial gyms, performance centres, and serious training facilities.

**Positioned as foundational equipment for serious facilities**





## QLI SUPER DUTY SPX RACK 1

MODEL: QSPX1



### DIMENSIONS

| Length               | Width                 | Height                | Net Weight         |
|----------------------|-----------------------|-----------------------|--------------------|
| 52 1/4"<br>(1322 mm) | 47 1/16"<br>(1212 mm) | 95 3/16"<br>(2418 mm) | 163 lbs<br>(74 kg) |

## QLI SUPER DUTY SPX RACK 2

MODEL: QSPX2



### DIMENSIONS

| Length               | Width                 | Height               | Net Weight          |
|----------------------|-----------------------|----------------------|---------------------|
| 47 3/8"<br>(1203 mm) | 49 3/16"<br>(1250 mm) | 94 1/2"<br>(2400 mm) | 266 lbs<br>(121 kg) |

## QLI POWER CAGE

MODEL: QPC98



### DIMENSIONS

| Length               | Width                | Height                 | Net Weight          |
|----------------------|----------------------|------------------------|---------------------|
| 79 1/8"<br>(2010 mm) | 51 3/8"<br>(1305 mm) | 98 13/16"<br>(2510 mm) | 429 lbs<br>(195 kg) |

## QLI POWER RACK

MODEL: QPR265



### DIMENSIONS

| Length                | Width                 | Height                 | Net Weight          |
|-----------------------|-----------------------|------------------------|---------------------|
| 101 3/4"<br>(2584 mm) | 75 3/16"<br>(1910 mm) | 98 13/16"<br>(2510 mm) | 583 lbs<br>(265 kg) |

**QLI POWER RACK**  
MODEL: QPR165



**DIMENSIONS**

| Length               | Width                | Height                 | Net Weight          |
|----------------------|----------------------|------------------------|---------------------|
| 86 5/8"<br>(2200 mm) | 51 3/8"<br>(1305 mm) | 98 13/16"<br>(2510 mm) | 363 lbs<br>(165 kg) |

**QLI POWER RACK**  
MODEL: QPR158



**DIMENSIONS**

| Length               | Width                 | Height                 | Net Weight          |
|----------------------|-----------------------|------------------------|---------------------|
| 86 5/8"<br>(2200 mm) | 35 13/16"<br>(910 mm) | 98 13/16"<br>(2510 mm) | 348 lbs<br>(158 kg) |

**QLI POWER SQUAT RACK**  
MODEL: QPSR02



**DIMENSIONS**

| Length                | Width                 | Height                 | Net Weight          | Weight Capacity     |
|-----------------------|-----------------------|------------------------|---------------------|---------------------|
| 77 9/16"<br>(1970 mm) | 33 11/16"<br>(855 mm) | 98 13/16"<br>(2510 mm) | 418 lbs<br>(190 kg) | 660 lbs<br>(300 kg) |

**QLI POWER RACK**  
MODEL: QPR350



**DIMENSIONS**

| Length                 | Width                | Height               | Net Weight          | Weight Capacity     |
|------------------------|----------------------|----------------------|---------------------|---------------------|
| 87 11/16"<br>(2228 mm) | 53 3/8"<br>(1355 mm) | 97 1/2"<br>(2476 mm) | 462 lbs<br>(210 kg) | 880 lbs<br>(400 kg) |

## QLI SQUAT RACK FRAME

MODEL: QSRF01



### DIMENSIONS

| Length                | Width                  | Height               | Net Weight          | Weight Capacity     |
|-----------------------|------------------------|----------------------|---------------------|---------------------|
| 87 1/16"<br>(2228 mm) | 64 15/16"<br>(1650 mm) | 92 7/8"<br>(2359 mm) | 341 lbs<br>(155 kg) | 550 lbs<br>(250 kg) |

## QLI SSTAIRCASE RIG – 2 CELLS

MODEL: QSR-2C

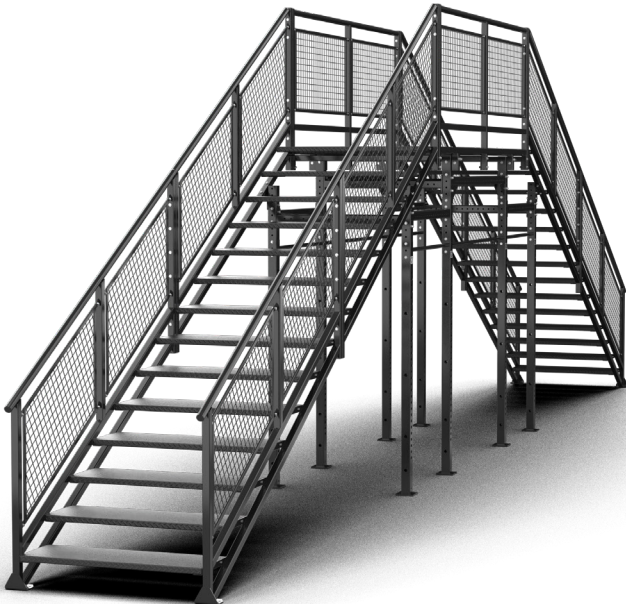

### DIMENSIONS

| Length                  | Width                 | Height                 | Net Weight              |
|-------------------------|-----------------------|------------------------|-------------------------|
| 512 3/16"<br>(13009 mm) | 57 1/16"<br>(1450 mm) | 157 5/16"<br>(3996 mm) | 4184.4 lbs<br>(1902 kg) |



# QLI POWERLIFTING DUAL RACK

MODEL: QPDR83

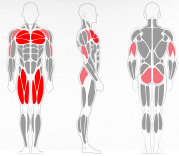

## DIMENSIONS

| Length                | Width            | Height               | Net Weight          | Weight Capacity      |
|-----------------------|------------------|----------------------|---------------------|----------------------|
| 86 9/16"<br>(2199 mm) | 75"<br>(1905 mm) | 56 1/8"<br>(1426 mm) | 436 lbs<br>(198 kg) | 1650 lbs<br>(750 kg) |



# ACCESSORIES

Complete your training environment with our comprehensive range of accessories, designed to enhance functionality, convenience, and workout efficiency.

From essential training tools to practical add-ons, QLI Fitness accessories are built to integrate seamlessly into professional and home gym setups - supporting consistent performance and a refined training experience.

**Elevated accessories from “extras” to performance enablers**



# COPIES



## QLI DOUBLE D HANDLE

MODEL: QDH008

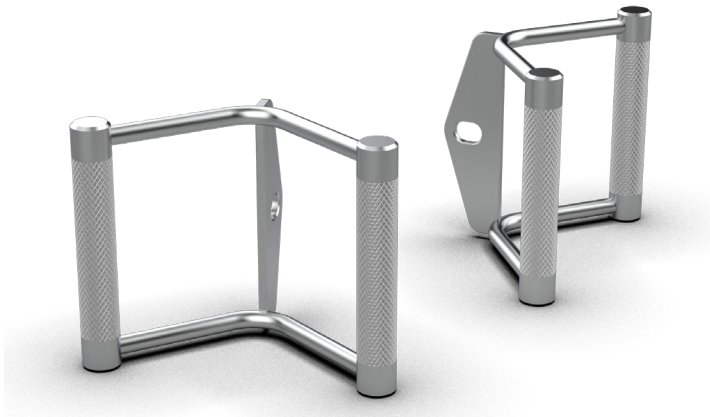

### DIMENSIONS



| Length              | Width               | Height             | Net Weight          | Weight Capacity     |
|---------------------|---------------------|--------------------|---------------------|---------------------|
| 8 1/16"<br>(205 mm) | 6 7/16"<br>(164 mm) | 4 7/8"<br>(124 mm) | 4.2 lbs<br>(1.9 kg) | 880 lbs<br>(400 kg) |

## QLI PULL UP BAR

MODEL: PUB1080



### DIMENSIONS

| Length               | Width              | Height             | Net Weight            |
|----------------------|--------------------|--------------------|-----------------------|
| 42 1/2"<br>(1080 mm) | 2 1/16"<br>(68 mm) | 5 7/8"<br>(150 mm) | 8.25 lbs<br>(3.75 kg) |

## QLI ADJUSTABLE LEVER ARMS

MODEL: QALA49



### DIMENSIONS

| Length                 | Width                | Height              | Net Weight           | Weight Capacity                        |
|------------------------|----------------------|---------------------|----------------------|--|
| 49 13/16"<br>(1265 mm) | 30 9/16"<br>(776 mm) | 13 1/8"<br>(333 mm) | 147.4 lbs<br>(67 kg) | 330 lbs (150 kg)<br>Each weight holder |

## QLI PULLEY CABLE ATTACHMENT

MODEL: QPCA12



### DIMENSIONS

| Length                | Width              | Height              | Net Weight         |
|-----------------------|--------------------|---------------------|--------------------|
| 12 15/16"<br>(328 mm) | 6 5/8"<br>(168 mm) | 8 1/16"<br>(205 mm) | 17.6 lbs<br>(8 kg) |

## QLI LAT PULLDOWN SEAT

MODEL: QLPS37



### DIMENSIONS

| Length              | Width               | Height                | Net Weight          |
|---------------------|---------------------|-----------------------|---------------------|
| 37 5/8"<br>(955 mm) | 23 7/8"<br>(607 mm) | 20 13/16"<br>(528 mm) | 72.6 lbs<br>(33 kg) |

## QLI WEIGHT PLATE STORAGE RACK ATTACHMENT

MODEL: QWSA16

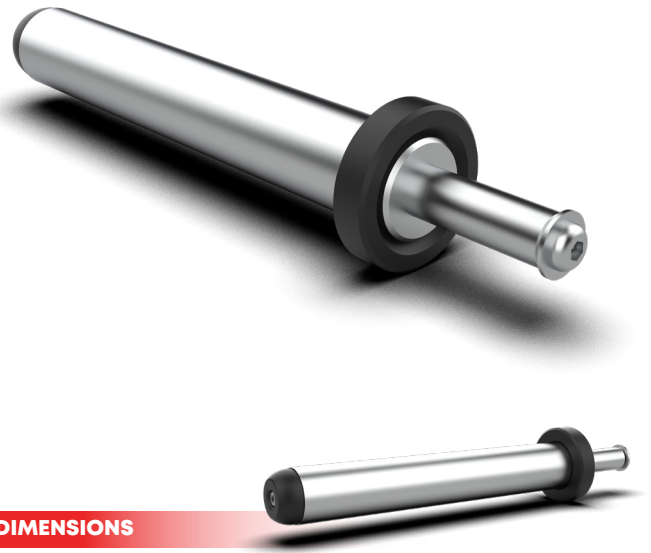

### DIMENSIONS

| Length               | Width             | Height            | Net Weight          | Weight Capacity                        |
|----------------------|-------------------|-------------------|---------------------|--|
| 16 1/16"<br>(424 mm) | 3 1/8"<br>(80 mm) | 3 1/8"<br>(80 mm) | 3.7 lbs<br>(1.7 kg) | 330 lbs (150 kg)<br>Each weight holder |

## QLI CABLE COLUMN ATTACHMENT

MODEL: QCCA40



### DIMENSIONS

| Length                | Width                 | Height              | Net Weight            | Weight Capacity             |
|-----------------------|-----------------------|---------------------|-----------------------|-----------------------------|
| 106 1/8"<br>(2696 mm) | 40 9/16"<br>(1030 mm) | 29 1/4"<br>(743 mm) | 556.6 lbs<br>(253 kg) | 242 lbs (110 kg)<br>Per set |

## QLI LEG CURL ATTACHMENT

MODEL: QLCA23

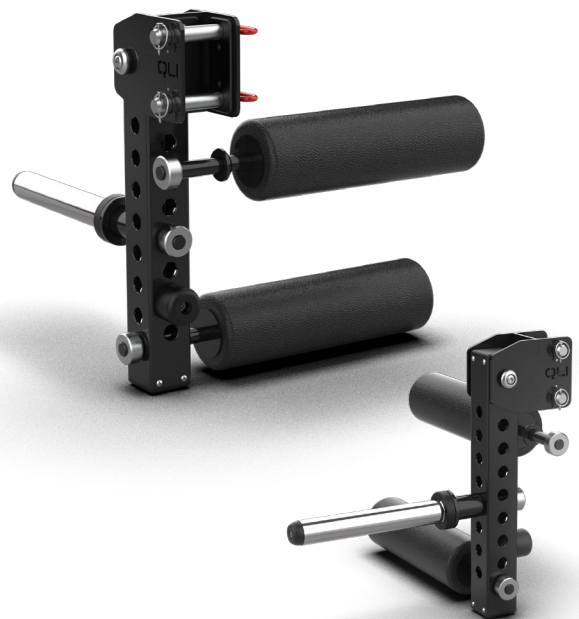

### DIMENSIONS

| Length               | Width                | Height              | Net Weight          | Weight Capacity                        |
|----------------------|----------------------|---------------------|---------------------|--|
| 23 7/16"<br>(595 mm) | 24 7/16"<br>(621 mm) | 23 1/8"<br>(588 mm) | 41.8 lbs<br>(19 kg) | 330 lbs (150 kg)<br>Each weight holder |

**QLI POWER J-HOOKS**  
MODEL: QPJH07



**DIMENSIONS**

| Length              | Width              | Height             | Net Weight          | Weight Capacity                |
|---------------------|--------------------|--------------------|---------------------|--------------------------------|
| 7 1/16"<br>(180 mm) | 3 1/16"<br>(93 mm) | 9 1/2"<br>(241 mm) | 9.2 lbs<br>(4.2 kg) | 2200 lbs (1000 kg)<br>Per pair |

**QLI SAFETY RACK STRAP SET**  
MODEL: QSR549



**DIMENSIONS**

| Length               | Width              | Height               | Net Weight            | Weight Capacity                |
|----------------------|--------------------|----------------------|-----------------------|--------------------------------|
| 49 5/8"<br>(1260 mm) | 6 1/8"<br>(155 mm) | 4 13/16"<br>(122 mm) | 29.7 lbs<br>(13.5 kg) | 2200 lbs (1000 kg)<br>Per pair |

**QLI PULL-UP  
BAR ATTACHMENT**  
MODEL: QPBA43



**DIMENSIONS**

| Length               | Width               | Height               | Net Weight            | Weight Capacity              |
|----------------------|---------------------|----------------------|-----------------------|------------------------------|
| 43 7/8"<br>(1115 mm) | 10 3/8"<br>(257 mm) | 5 13/16"<br>(147 mm) | 23.3 lbs<br>(10.6 kg) | 440 lbs (200 kg)<br>Per pair |

**QLI SQUAT RACK FRAME**  
MODEL: QSRF77



**DIMENSIONS**

| Length                | Width               | Height                 | Net Weight           | Weight Capacity              |
|-----------------------|---------------------|------------------------|----------------------|------------------------------|
| 77 9/16"<br>(1970 mm) | 9 7/16"<br>(240 mm) | 94 13/16"<br>(2408 mm) | 147.4 lbs<br>(67 kg) | 660 lbs (300 kg)<br>Per pair |

## QLI LEG PRESS ATTACHMENT

MODEL: QLPA51

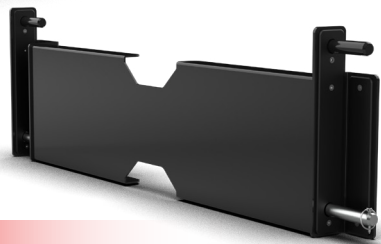

### DIMENSIONS

| Length                | Width                | Height             | Net Weight          | Weight Capacity                        |
|-----------------------|----------------------|--------------------|---------------------|--|
| 51 3/16"<br>(1300 mm) | 15 3/16"<br>(385 mm) | 4 1/2"<br>(114 mm) | 52.8 lbs<br>(24 kg) | 330 lbs (150 kg)<br>Each weight holder |

## QLI ADJUSTABLE JAMMER ARMS

MODEL: QAJA14

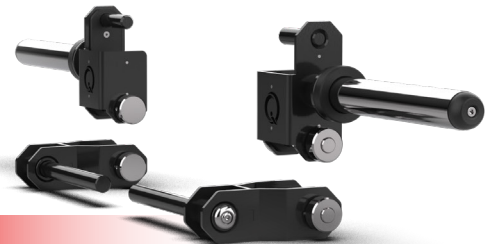

### DIMENSIONS

| Length               | Width               | Height              | Net Weight        | Weight Capacity                        |
|----------------------|---------------------|---------------------|-------------------|--|
| 14 3/16"<br>(356 mm) | 8 7/16"<br>(214 mm) | 2 15/16"<br>(75 mm) | 44 lbs<br>(20 kg) | 330 lbs (150 kg)<br>Each weight holder |

## QLI FLAT WEIGHT BENCH ATTACHMENT

MODEL: QFWBA48



### DIMENSIONS

| Length                 | Width                | Height             | Net Weight          | Weight Capacity             |
|------------------------|----------------------|--------------------|---------------------|-----------------------------|
| 52 15/16"<br>(1344 mm) | 11 7/16"<br>(290 mm) | 4 1/2"<br>(115 mm) | 26.4 lbs<br>(12 kg) | 330 lbs (150 kg)<br>Per set |

## QLI SAFETY BARS

MODEL: QSB49



### DIMENSIONS

| Length                | Width               | Height             | Net Weight          | Weight Capacity                |
|-----------------------|---------------------|--------------------|---------------------|--------------------------------|
| 49 7/16"<br>(1255 mm) | 9 3/16"<br>(230 mm) | 3 9/16"<br>(90 mm) | 59.4 lbs<br>(27 kg) | 2200 lbs (1000 kg)<br>Per pair |

## QLI UTILITY SEAT SET MODEL: QUSS48



### DIMENSIONS

| Length               | Width               | Height             | Net Weight          | Weight Capacity     |
|----------------------|---------------------|--------------------|---------------------|---------------------|
| 48 1/4"<br>(1225 mm) | 13 3/4"<br>(350 mm) | 3 3/16"<br>(81 mm) | 52.8 lbs<br>(24 kg) | 990 lbs<br>(450 kg) |



## QLI BARBELL HANGER RACK MODEL: QBHR11



### DIMENSIONS

| Length                | Width              | Height              | Net Weight        | Weight Capacity              |
|-----------------------|--------------------|---------------------|-------------------|------------------------------|
| 11 13/16"<br>(300 mm) | 6 7/8"<br>(174 mm) | 2 15/16"<br>(75 mm) | 6.6 lbs<br>(3 kg) | 440 lbs (200 kg)<br>Per pair |

## QLI CABLE PULLEY SYSTEM MODEL: QCPS23

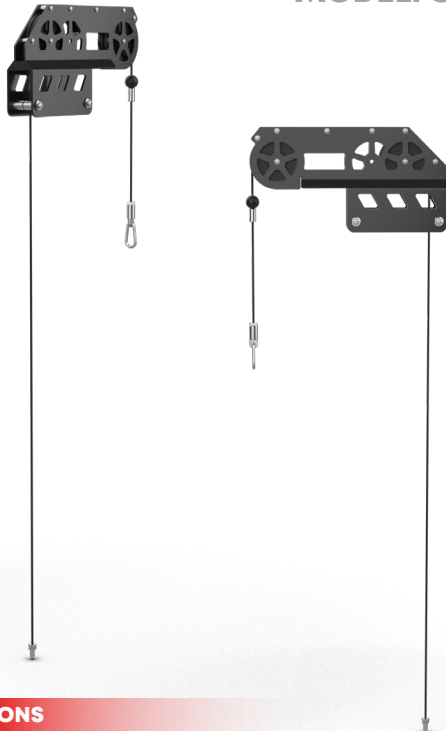

### DIMENSIONS

| Length              | Width                | Height             | Net Weight          |
|---------------------|----------------------|--------------------|---------------------|
| 23 3/8"<br>(593 mm) | 12 5/16"<br>(313 mm) | 4 1/2"<br>(115 mm) | 30.8 lbs<br>(14 kg) |

## QLI DIP BAR ATTACHMENT MODEL: QDBA27



### DIMENSIONS

| Length          | Width                 | Height             | Net Weight          | Weight Capacity             |
|-----------------|-----------------------|--------------------|---------------------|-----------------------------|
| 27"<br>(686 mm) | 26 15/16"<br>(685 mm) | 7 7/8"<br>(200 mm) | 28.6 lbs<br>(13 kg) | 660 lbs (300 kg)<br>Per set |

## QLI CHEST SUPPORT ATTACHMENT

MODEL: QCSA26

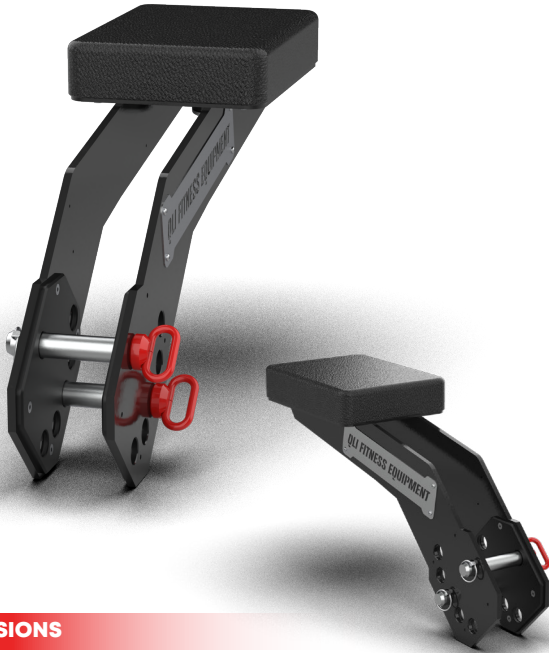

### DIMENSIONS

| Length              | Width               | Height               | Net Weight          | Weight Capacity              |
|---------------------|---------------------|----------------------|---------------------|------------------------------|
| 14 7/8"<br>(378 mm) | 14 3/8"<br>(365 mm) | 8 11/16"<br>(220 mm) | 30.8 lbs<br>(14 kg) | 660 lbs (300 kg)<br>Per pair |

## QLI WEIGHT STACK SET

MODEL: QWSS9

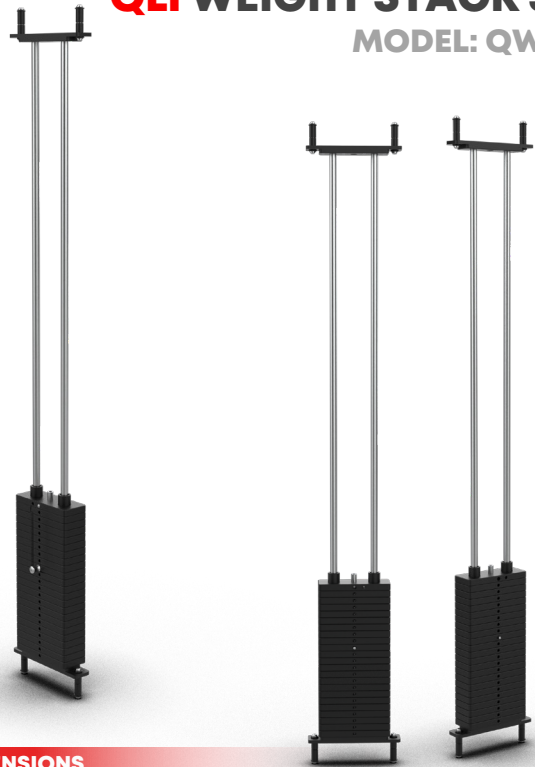

### DIMENSIONS

| Length                | Width               | Height             | Net Weight            | Weight Capacity             |
|-----------------------|---------------------|--------------------|-----------------------|-----------------------------|
| 94 9/16"<br>(2402 mm) | 13 3/4"<br>(350 mm) | 4 1/8"<br>(105 mm) | 279.4 lbs<br>(127 kg) | 242 lbs (110 kg)<br>Per set |

## QLI LAT PULLDOWN BAR

MODEL: QLPB42



### DIMENSIONS

| Length                | Width              | Height             | Net Weight        |
|-----------------------|--------------------|--------------------|-------------------|
| 42 7/16"<br>(1078 mm) | 6 1/8"<br>(156 mm) | 1 9/16"<br>(40 mm) | 6.6 lbs<br>(3 kg) |

## QLI CABLE CROSSOVER ATTACHMENT

MODEL: QCCA106



### DIMENSIONS

| Length                | Width                | Height                 | Net Weight            | Weight Capacity             |
|-----------------------|----------------------|------------------------|-----------------------|-----------------------------|
| 106 1/8"<br>(2696 mm) | 66 7/8"<br>(1698 mm) | 55 15/16"<br>(1421 mm) | 565.4 lbs<br>(257 kg) | 242 lbs (110 kg)<br>Per set |

## QLI ADJUSTABLE LEVER ARMS

MODEL: QALA80



### DIMENSIONS

| Length               | Width                  | Height               | Net Weight            | Weight Capacity                        |
|----------------------|------------------------|----------------------|-----------------------|--|
| 80 1/2"<br>(2044 mm) | 49 13/16"<br>(1265 mm) | 18 1/16"<br>(459 mm) | 246.4 lbs<br>(112 kg) | 330 lbs (150 kg)<br>Each weight holder |

## QLI BARBELL STORAGE RACK ATTACHMENT

MODEL: QBSA04



### DIMENSIONS

| Length              | Width             | Height              | Net Weight          |
|---------------------|-------------------|---------------------|---------------------|
| 8 1/16"<br>(221 mm) | 2 3/8"<br>(60 mm) | 4 3/16"<br>(106 mm) | 3.7 lbs<br>(1.7 kg) |

## QLI RIG UPRIGHT

MODEL: QRU98



### DIMENSIONS

| Length             | Width              | Height                 | Net Weight          |
|--------------------|--------------------|------------------------|---------------------|
| 5 7/8"<br>(150 mm) | 5 7/8"<br>(150 mm) | 98 13/16"<br>(2510 mm) | 35.2 lbs<br>(16 kg) |

## QLI CONNECTING BAR

MODEL: QCB42



### DIMENSIONS

| Length               | Width              | Height              | Net Weight         |
|----------------------|--------------------|---------------------|--------------------|
| 42 1/2"<br>(1080 mm) | 7 1/2"<br>(190 mm) | 2 15/16"<br>(75 mm) | 17.6 lbs<br>(8 kg) |

**QLI CONNECTING BAR**  
MODEL: QCB24

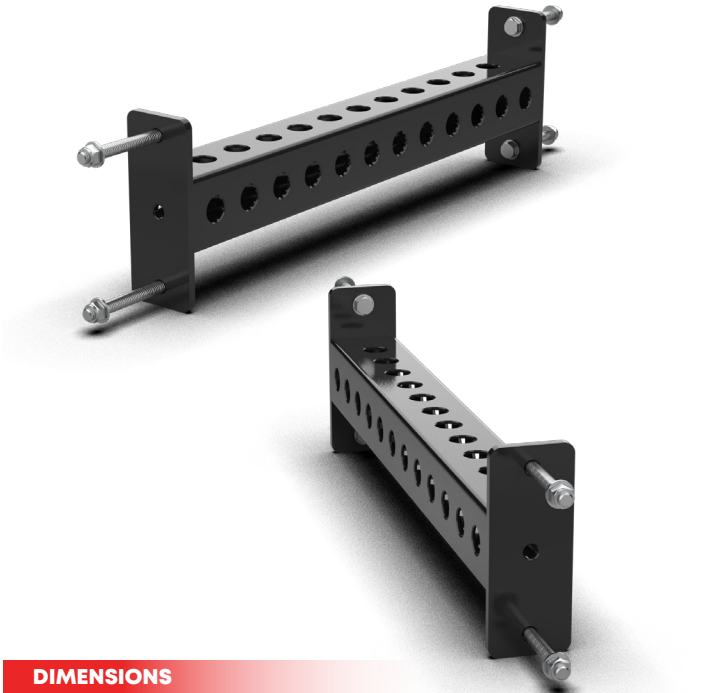

**DIMENSIONS**

| Length                | Width              | Height              | Net Weight         |
|-----------------------|--------------------|---------------------|--------------------|
| 24 13/16"<br>(630 mm) | 7 1/2"<br>(190 mm) | 2 15/16"<br>(75 mm) | 13.2 lbs<br>(6 kg) |

**QLI CONNECTING BAR**  
MODEL: QCB2401

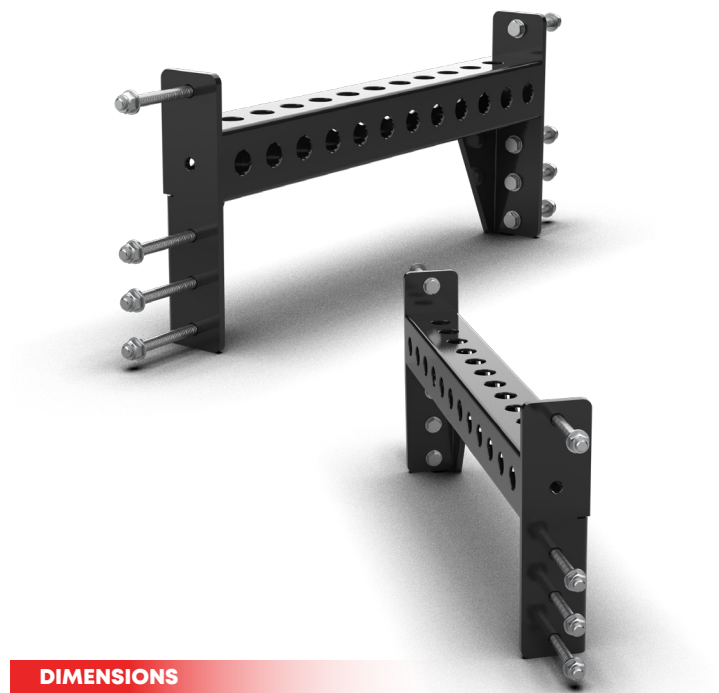

**DIMENSIONS**

| Length                | Width                | Height              | Net Weight         |
|-----------------------|----------------------|---------------------|--------------------|
| 24 13/16"<br>(630 mm) | 11 7/16"<br>(290 mm) | 2 15/16"<br>(75 mm) | 17.6 lbs<br>(8 kg) |

**QLI CONNECTING BAR**  
MODEL: QCB4201

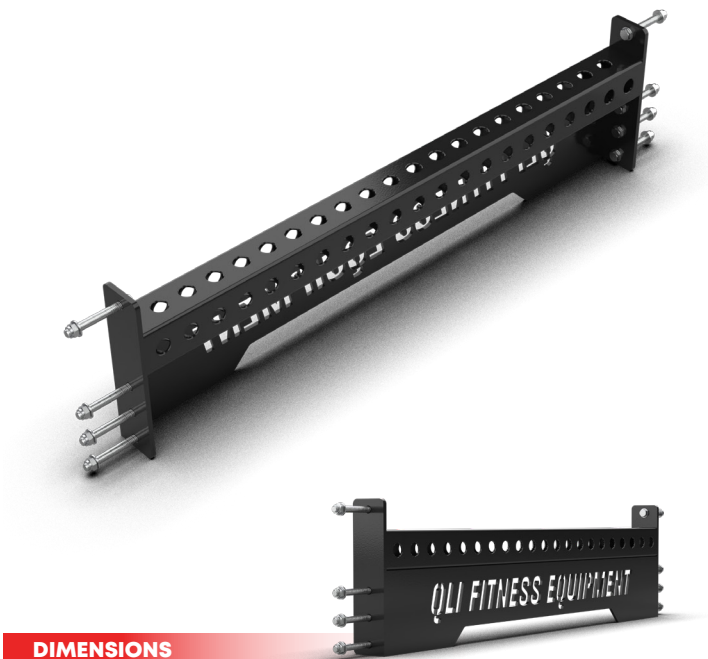

**DIMENSIONS**

| Length               | Width                | Height              | Net Weight        |
|----------------------|----------------------|---------------------|-------------------|
| 42 1/2"<br>(1080 mm) | 11 7/16"<br>(290 mm) | 2 15/16"<br>(75 mm) | 33 lbs<br>(15 kg) |

**QLI CONNECTING BAR**  
MODEL: QCB4202



**DIMENSIONS**

| Length               | Width                | Height              | Net Weight          |
|----------------------|----------------------|---------------------|---------------------|
| 42 1/2"<br>(1080 mm) | 11 7/16"<br>(290 mm) | 2 15/16"<br>(75 mm) | 24.2 lbs<br>(11 kg) |

## QLI SAFETY SPOTTER ARMS

MODEL: QSA024

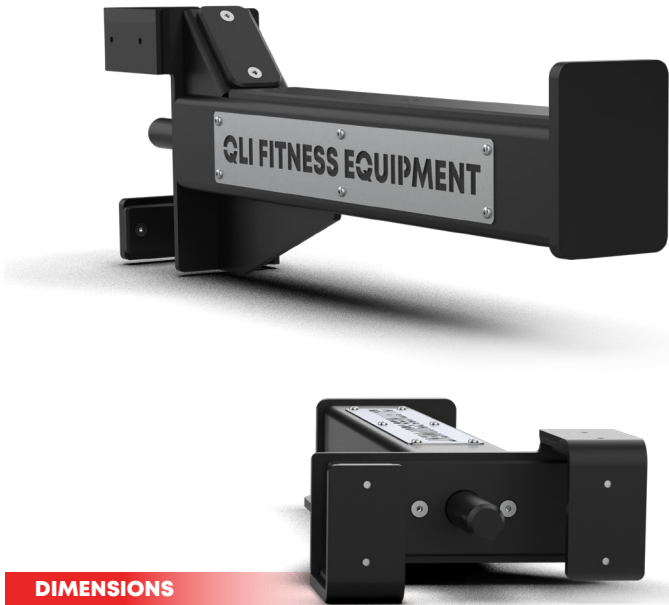

### DIMENSIONS

| Length              | Width              | Height             | Net Weight        | Weight Capacity                |
|---------------------|--------------------|--------------------|-------------------|--------------------------------|
| 24 1/8"<br>(613 mm) | 8 1/8"<br>(207 mm) | 4 1/8"<br>(105 mm) | 33 lbs<br>(15 kg) | 2200 lbs (1000 kg)<br>Per pair |

## QLI STIRRUP HANDLE

MODEL: QSH006



### DIMENSIONS

| Length              | Width              | Height             | Net Weight           |
|---------------------|--------------------|--------------------|----------------------|
| 6 7/16"<br>(164 mm) | 6 3/8"<br>(162 mm) | 1 3/16"<br>(30 mm) | 1.32 lbs<br>(0.6 kg) |

## QLI TRIANGLE GRIP HANDLE

MODEL: QTGH07



### DIMENSIONS

| Length               | Width               | Height               | Net Weight        |
|----------------------|---------------------|----------------------|-------------------|
| 7 11/16"<br>(195 mm) | 6 9/16"<br>(166 mm) | 6 15/16"<br>(176 mm) | 6.6 lbs<br>(3 kg) |

## QLI LANDMINE RACK ATTACHMENT

MODEL: QLRA19

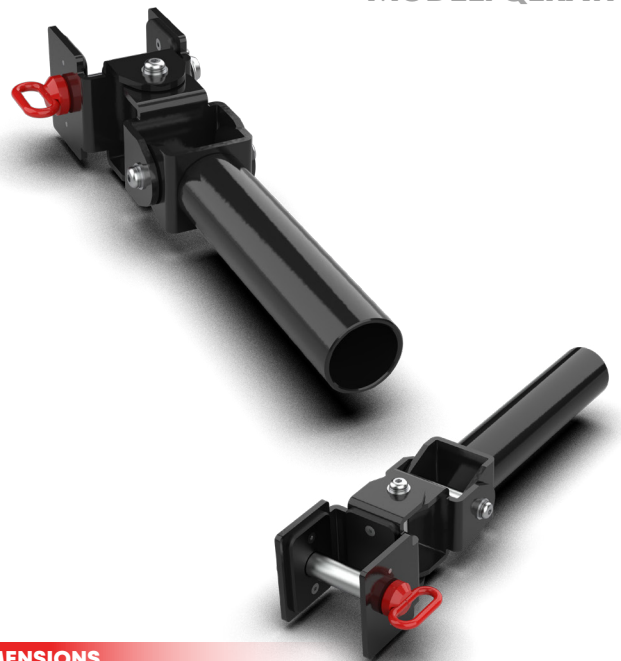

### DIMENSIONS

| Length              | Width              | Height               | Net Weight       |
|---------------------|--------------------|----------------------|------------------|
| 19 1/4"<br>(489 mm) | 6 5/8"<br>(168 mm) | 4 11/16"<br>(119 mm) | 11 lbs<br>(5 kg) |

**QLI FIXED BARBELL**  
MODEL: QLFB01

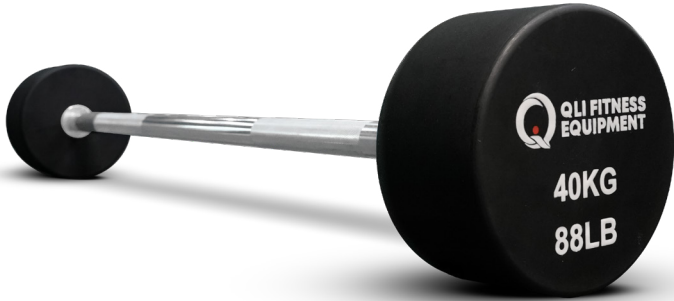

**QLI EZ CURL BARBELL**  
MODEL: QLCB01



**DIMENSIONS**



| Length                                 | Width                               | Height                              | Net Weight                   |
|--|-------------------------------------|-------------------------------------|------------------------------|
| 39 3/4" - 46 1/16"<br>(1010 - 1170 mm) | 4 15/16" - 7 1/2"<br>(125 - 190 mm) | 4 15/16" - 7 1/2"<br>(125 - 190 mm) | 22 - 110 lbs<br>(10 - 50 kg) |

**DIMENSIONS**



| Length                                 | Width                               | Height                              | Net Weight                   |
|--|-------------------------------------|-------------------------------------|------------------------------|
| 39 3/4" - 46 1/16"<br>(1010 - 1170 mm) | 4 15/16" - 7 1/2"<br>(125 - 190 mm) | 4 15/16" - 7 1/2"<br>(125 - 190 mm) | 22 - 110 lbs<br>(10 - 50 kg) |

**QLI BARBELL**  
MODEL: QB086



**DIMENSIONS**

| Length               | Width             | Height            | Net Weight        | Weight Capacity     |
|----------------------|-------------------|-------------------|-------------------|---------------------|
| 86 5/8"<br>(2200 mm) | 3 3/8"<br>(80 mm) | 3 3/8"<br>(80 mm) | 33 lbs<br>(15 kg) | 880 lbs<br>(400 kg) |

**QLI WEIGHT PLATES**  
MODEL: QWS007



**DIMENSIONS**

| Length                                | Width                                 | Height                            | Net Weight                    |
|---------------------------------------|---------------------------------------|-----------------------------------|-------------------------------|
| 9 7/16" - 15 15/16"<br>(240 - 405 mm) | 9 7/16" - 15 15/16"<br>(240 - 405 mm) | 15/16" - 1 15/16"<br>(25 - 50 mm) | 5.5 - 55 lbs<br>(2.5 - 25 kg) |

## QLI HEXAGON DUMBBELL

MODEL: QDS016



### DIMENSIONS

| Length                               | Width                              | Height                           | Net Weight                     |
|--------------------------------------|------------------------------------|----------------------------------|--------------------------------|
| 10 3/16" - 17 3/8"<br>(255 - 435 mm) | 3 9/16" - 9 3/16"<br>(90 - 230 mm) | 3 1/8" - 7 7/8"<br>(80 - 200 mm) | 5.5 - 110 lbs<br>(2.5 - 50 kg) |

## QLI KETTLEBELL SET

MODEL: QKS014



### DIMENSIONS

| Length                             | Width                               | Height                              | Net Weight                    |
|------------------------------------|-------------------------------------|-------------------------------------|-------------------------------|
| 6 1/8" - 8 7/16"<br>(155 - 215 mm) | 3 15/16" - 7 7/8"<br>(100 - 200 mm) | 7 1/16" - 12 5/8"<br>(180 - 320 mm) | 8.8 - 70.4 lbs<br>(4 - 32 kg) |





# QLI FITNESS EQUIPMENT



WEBSITE

## Get in touch with our Sales Team

📍 14524 Garfield Ave, Paramount, CA 90723 USA

✉️ [sales@qlifitnessequipment.com](mailto:sales@qlifitnessequipment.com)

☎️ +1 (562) 239-5382



## POWER YOUR LIFESTYLE

AUSTRALIA | VIETNAM | USA